

AV30

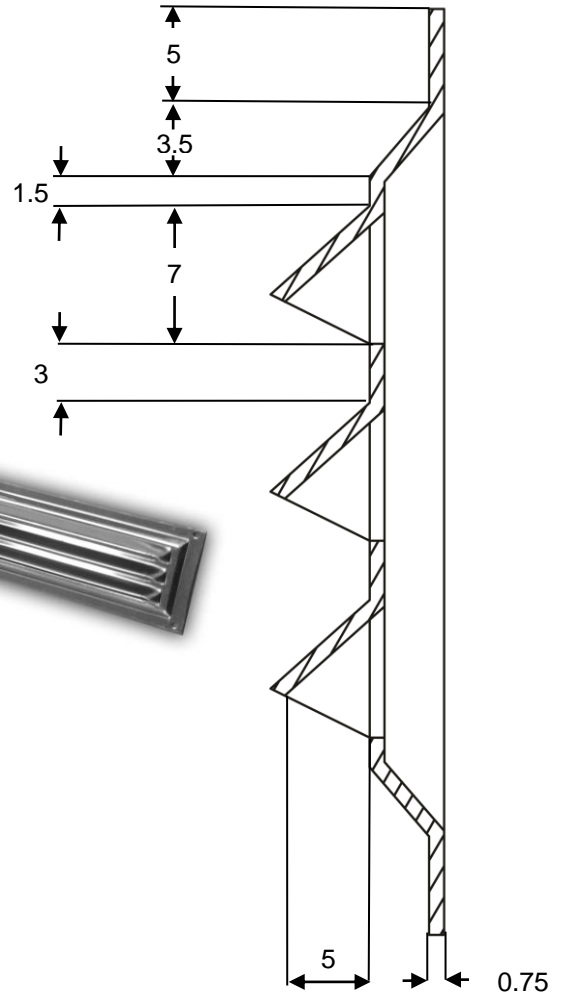

CROSS SECTION THROUGH VENT

General

Specified by British Gas. AV30 is used to vent heating appliances and is commonly fitted over a series of 32mm. Ø holes. Suitable for use in a wide variety of applications.

Details

REF	AV30	MANUFACTURING PROCESS	Pressed
SIZE MM	762 x 50	MATERIAL	Anodised Aluminium
FREE AREA	129cm ²		
kW AREA	N/A	COLOUR	Silver
PACKING	50 per box		
WEIGHT	88 grams each		

References BS5440 Pt.2:2000

Version 1.0	02/02/2007	DRN DEW	DRG No. AF-AV30 -005
-------------	------------	---------	----------------------

Airflow (Nicoll Ventilators) Limited, 15 Queensway, Stem Lane Industrial Estate, New Milton, Hampshire, BH25 5NN
Telephone: 01425 611547 FAX:01425 638912 e-mail:sales@airflow-vent.co.uk
Made in the UK

Due to continuous development Airflow (Nicoll Ventilators) Limited reserves the right to amend the specification without notice.